

info@micro-lam.com

www.micro-lam.com

Micro-LAM Technologies
4950 W Dickman Rd, Ste AA1
Battle Creek, Michigan, 49037
+1(269) 288 - 4100



Cutting Edge Precision
Laser Focused

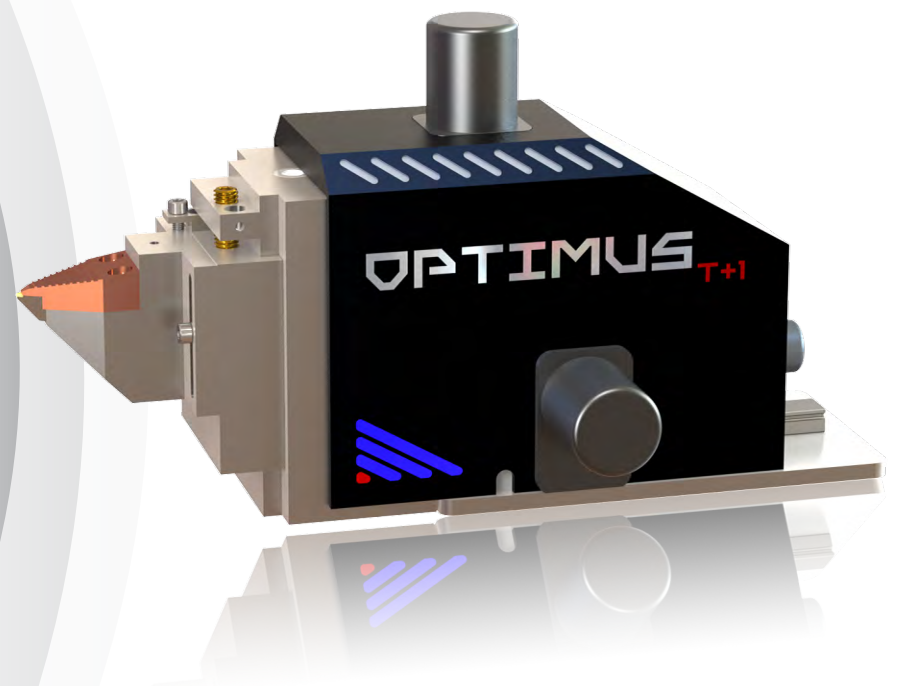

Improve Part Quality

Extend Tool Life

Increase Throughput

Quick Payback

The Patented Solution

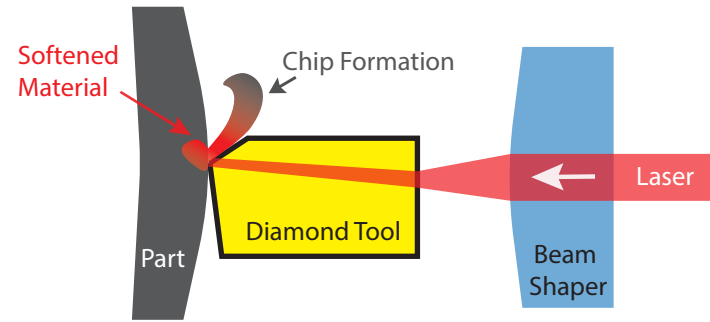

- ◆ The laser beam passes through an optically transparent diamond tool.
- ◆ Laser delivered precisely at tool-workpiece interface
- ◆ Innovative solution proven through extensive research & development
- ◆ Issued patent with 20 claims

Optimus_{T+1} Key Components

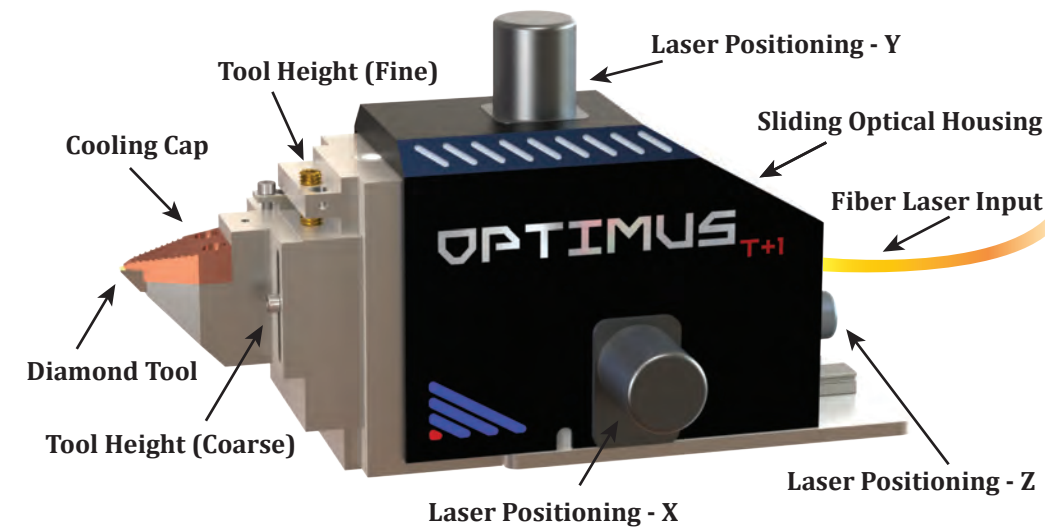

- The Optimus_{T+1} tool post also accommodates conventional diamond tools.
- The optical assembly is isolated from the tooling for enhanced stability.

Proprietary Tool Design

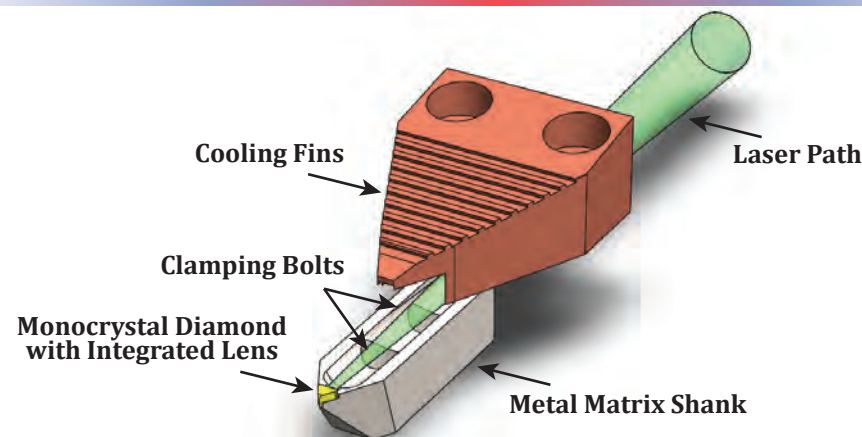

Silicon

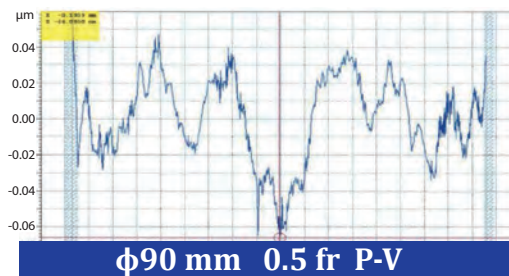
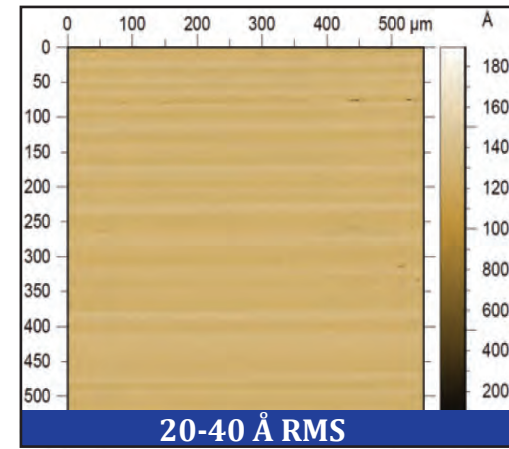

- Faster part machining (2-5x)
- Improved surface finish (2-4x)
- Extended tool life (3-7x)
- Improved form accuracy with correction
- No spoking or surface damage
- Less rainbow effect
- Part diameter: 12-375 mm

Zinc Sulfide

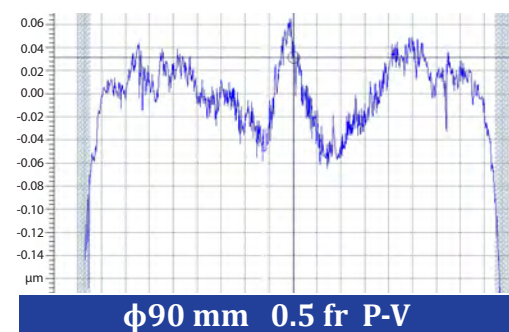
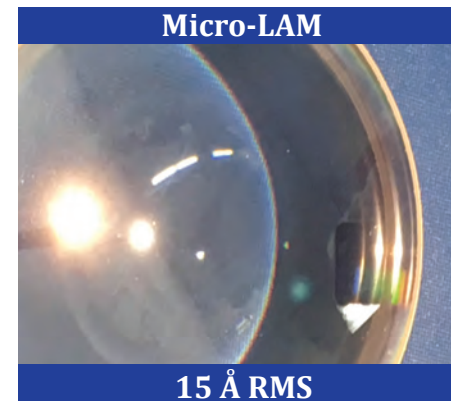
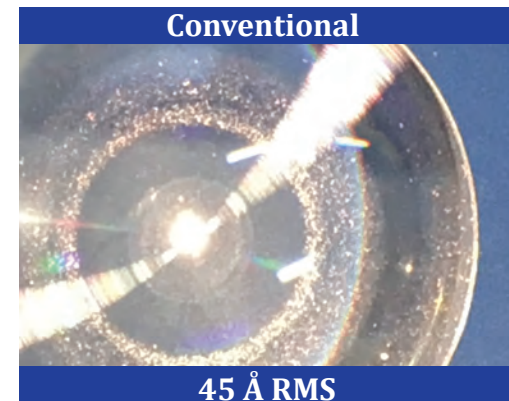

- Faster part machining (2-5x)
- Improved surface finish (2-4x)
- Extended tool life (2-4x)
- Improved form accuracy with correction
- No haze or pitting

Calcium Fluoride

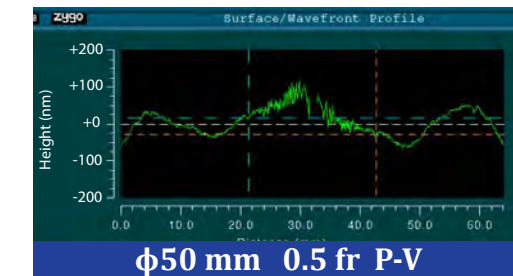
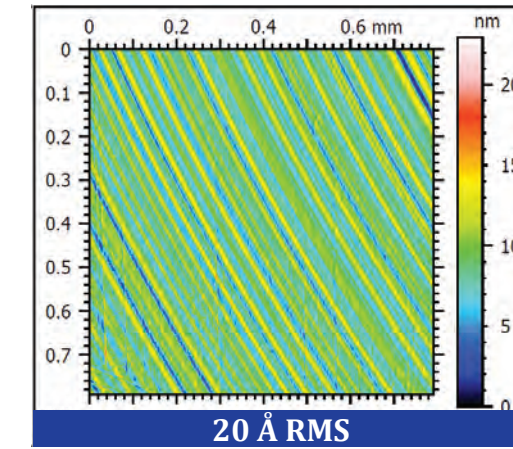

- Faster part machining (3-5x)
- Improved surface finish (2-4x)
- Extended tool life (6-8x)
- Improved form accuracy with correction
- No visible pitting or spoking
- Allows use of low grade material

Tungsten Carbide

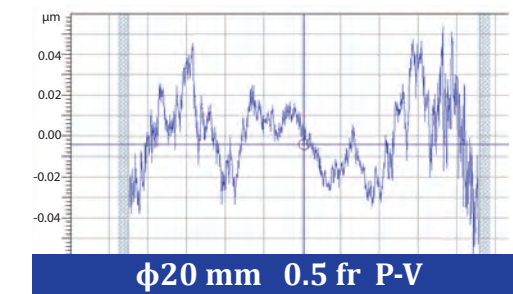
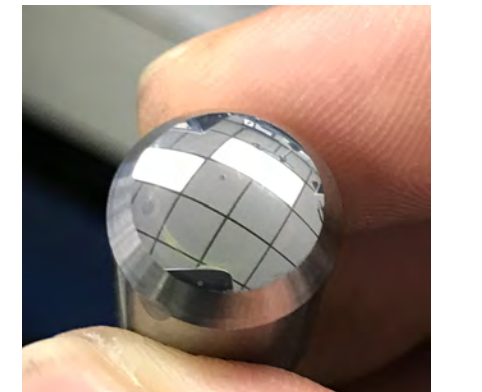
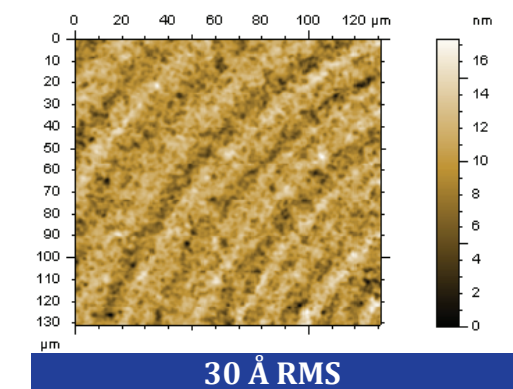

- Optical glass press mold tooling
- Injection mold tooling
- 10X faster than grinding
- Improved accuracy & surface quality
- Tool path correction capable

Materials Testing in Progress

Silicon Carbide	Barium Fluoride	E-Nickel
Stainless Steel	Aluminum	Copper
Zinc Selenide	Sapphire	Glass
Germanium	Beryllium	Spinel